

DAVEY WATER PRODUCTS GUARANTEE FOR AUSTRALIA & NEW ZEALAND

This Davey product is guaranteed to be free of material or manufacturing defects at the time of original purchase. Should any part fail as a result of such defects within two years of original purchase, the product will be repaired free of charge.

TERMS AND CONDITIONS

1. This guarantee applies to all states and territories of Australia and New Zealand only and is subject to the provisions of the Trade Practices Act (Aust.), the Goods and Consumer Protection Legislation of the various Australian states and the Consumers Guarantee Act 1993 (NZ) as applicable.
2. The guarantee period commences on the date of original purchase of the equipment. Evidence of this date of original purchase must be provided when claiming repairs under guarantee. It is recommended you retain all receipts in a safe place.
3. This guarantee covers parts and workshop labour only. Goods should be forwarded, with proof of date of original purchase, to an Authorised Davey Service Centre freight paid.
4. This guarantee is subject to due compliance by the original purchaser with all directions and conditions set out in the Installation and Operating Instructions. Failure to comply with these instructions, damage or breakdown caused by fair wear and tear, negligence, misuse, incorrect installation, chemical or additives in the water, inadequate protection against freezing, rain or other adverse weather conditions, corrosive or abrasive water, lightning or high voltage spikes or through unauthorised persons attempting repairs are not covered under guarantee. The product must only be connected to the voltage shown on the nameplate.
5. Without limiting the original purchaser's entitlements under the Trade Practices Act (Aust.), the Goods & Consumer Protection Legislation of the various Australian states, or the Consumers Guarantee Act 1993 (NZ), Davey shall not be liable for any loss of profits or any consequential, indirect or special loss, damage or injury of any kind whatsoever arising directly or indirectly from the product or any defect.
6. Where the Trade Practices Act (Aust.), the Goods and Consumer Protection Legislation of the various Australian states and the Consumers Guarantee Act 1993 (NZ) does not apply, Davey shall not be liable for any loss of profits or any consequential, indirect or special loss, damage or injury of any kind whatsoever suffered by the purchaser arising directly or indirectly from the product or any defect and the purchaser shall indemnify Davey against any claim by any other person whatsoever in respect of any such loss, damage or injury.
7. Nothing in this guarantee is intended to have the effect of contracting out of the provisions of the Trade Practices Act (Aust.), the Goods and Consumer Protection Legislation of the various Australian states and Consumers Guarantee Act 1993 (NZ) except to the extent permitted by the various Acts and this guarantee is to be modified to the extent necessary to give effect to that intention.
8. Davey may be collecting personal information from you in order to provide you with a service. Davey Water Products Pty Ltd promises only to use this information in accordance with the Provisions of the Privacy Act 1988 (Cth) and the Privacy Policy of Davey Water Products Pty Ltd which is available at davey.com.au.

© Davey is a registered trademark of Davey Water Products Pty Ltd. © Davey Water Products Pty Ltd 2006.

Davey Water Products Pty Ltd

Member of the GUD Group
ABN 18 066 327 517

Head Office and Manufacturing

6 Lakeview Drive,
Scoresby, Australia 3179
Ph: +61 3 9730 9222
Fax: +61 3 9753 4100
Website: davey.com.au

Customer Service Centre

Ph: 1300 367 866
Fax: 1300 369 119
E-mail: sales@davey.com.au

Interstate Offices

Sydney • Brisbane • Adelaide
Perth • Townsville

International

6 Lakeview Drive,
Scoresby, Australia 3179
Ph: +61 3 9730 9121
Fax: +61 3 9753 4248
E-mail: export@davey.com.au

Germany

Kantstrasse 47,
04275 Leipzig
Ph: +49 341 301 0412
Fax: +49 341 301 0413
E-mail: akrenz@daveyeurope.com

New Zealand

7 Rockridge Avenue,
Penrose, Auckland 1061
Ph: +64 9 570 9135
Fax: +64 9 527 7654
Website: daveynz.co.nz
E-mail: sales@daveynz.co.nz

USA

Davey Pumps Inc.
1005 N. Commons Drive
Aurora, Illinois 60504
Ph: +1 630 898 6976
Fax: +1 630 851 7744
Website: daveyusa.com
E-mail: sales@daveyusa.com

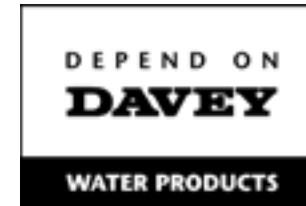

Installation and Operating Instructions for HM Series Electric Pumps

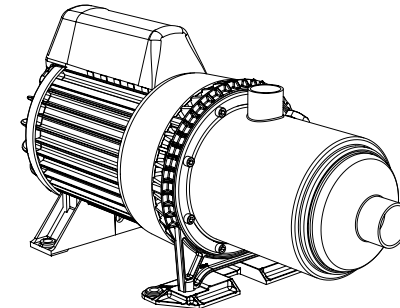

NOTE: Prior to installation remove the red transport plugs & associated seals from the suction and/or discharge ports.



WARNING : The pump and associated pipework operate under pressure. Under no circumstances should the pump or associated pipework be disassembled unless the internal pressure of the unit has been relieved. Failure to observe this warning will expose persons to the possibility of personal injury and may also result in damage to the pump, pipework or other property.



WARNING: Failure to follow these instructions and comply with all applicable codes may cause serious bodily injury and/or property damage.

Please pass these instructions on to the operator of this equipment.

Prior to using this pump you must ensure that:

- The pump is installed in a safe and dry environment
- The pump enclosure has adequate drainage in the event of leakage
- Any transport plugs are removed
- The pipe-work is correctly sealed and supported
- The pump is primed correctly
- The power supply is correctly connected
- All steps have been taken for safe operation

Appropriate details for all of these items are contained in the following Installation and Operating Instructions. Read these in their entirety before switching on this pump. If you are uncertain as to any of these Installation and Operating Instructions please contact your Davey dealer or the appropriate Davey office as listed on the back of this document.

Congratulations on your purchase of a high quality, Australian built Davey multistage pump. All components have been designed and manufactured to give trouble free, reliable operation.

Before installing your new pump, please read all instructions carefully as failures caused by incorrect installation or operation are not covered by the guarantee. Your HM Electric Pump is designed to handle clean water. The pump should not be used for any other purpose without specific referral to Davey. The use of the pump to pump flammable, corrosive and other materials of a hazardous nature is specifically excluded.

General

Applications

Pumps for clear liquids, free of abrasives in residential, agricultural, industrial, and other applications.

In accordance with AS 3350.2.41 we are obliged to inform you that this pump is not to be used by children or infirm persons and must not be used as a toy by children.

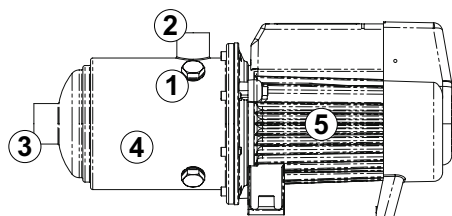



1. Priming Plug
2. Discharge Outlet
(1" BSPF)
3. Suction Inlet (1 1/4" BSPF)
4. Pump Body
5. Motor

Specifications

Max. service pressure:	1000kPa
Max. inlet pressure:	600kPa
Liquid temperate range:	-15 to +105°C
Ambient temperature:	0 to 50°C
Suction head:	depends on NPSH of pump

 ***NOTE "MOTOR PROTECTION DEVICE" :**
For protection, the Davey pump motor is fitted with an automatic reset thermal overload, constant tripping of this overload indicates a problem e.g. low voltage at pump, excessive temperature (above 50°C) in pump enclosure.

 **WARNING:** Automatic reset thermal overloads will allow the pump to restart without warning. Always disconnect the pump motor from the electrical supply before maintenance or repairs.

 **WARNING:** When servicing or attending pump, always ensure power is switched off and lead unplugged. Electrical connections should be serviced only by qualified persons.

 Care should also be taken when servicing or disassembling pump to avoid possible injury from hot pressurised water. Unplug pump, relieve pressure by opening a tap on the discharge side of the pump and allow any hot water in the pump to cool before attempting to dismantle.

 **IMPORTANT:**
DO NOT USE petroleum based fluids or solvents (e.g. Oils, Kerosene, Turpentine, Thinners, etc) on the plastic pump components or seal components.

 **WARNING:** Do not use hydrocarbon based or hydrocarbon propelled sprays around the electrical components of this pump.

After Sales Service

For professional after sales service or repair contact your Davey Dealer.
For assistance in locating your nearest dealer contact the Davey Customer Service Centre as appropriate and listed on the back of this document.



Choosing a Site

Choose a site with a firm base as close to the water source as possible with correct power supply. Make sure your pump is always connected to an adequate, reliable source of clean water.

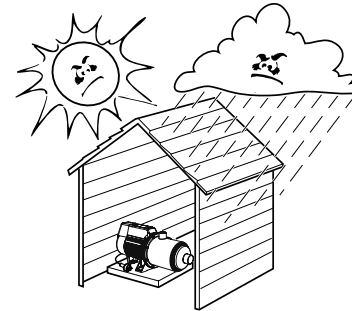
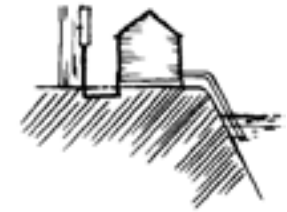



Housing your Davey Pump

To protect your pump from the weather, make sure the pump house is both water proof, frost free and has adequate ventilation. The pump should be mounted on a firm base allowing for drainage, to avoid damage to flooring etc., that over time may occur from leaking pipe joints or pump seals. Do not mount the pump vertically. Never place flammable materials on or near your pump.

Power Connection

 Connect lead to power supply designated on pump label, do not use long extension leads as they cause substantial voltage drop, poor pump performance and may cause motor overload.

 The electrical connections and checks must be made by a qualified electrician and comply with applicable local standards. Poor installation or poor power supply may even result in electrical fires!

 **NOTE:**

1. Ensure motor is connected to power supply specified on nameplate.
2. Avoid long extension leads as they can cause substantial voltage drop and operating problems.
3. Although the Davey electric motor is specifically engineered to perform on a range of power supply voltages, malfunctions or failure caused by adverse voltage supply conditions are not covered under guarantee.

 In accordance with AS 3350.2.41 we are obliged to inform you that this pump is not to be used by children or infirm persons and must not be used as a toy by children.

Single Phase

The single phase models which are supplied with a 10 amp plug may be plugged into a standard 10amp outlet. Model with the special 15 amp power plug may only be used with the appropriate 15 amp 220/250V power outlet (15 amp power outlets are usually specially provided by an electrician).

Always ensure that the earth conductor in the lead is connected to a good earth.

All single phase Models have automatic re-set thermal overload protection built in, i.e. should overload on motor cause thermal to open circuit and switch motor off, it will automatically re-set and switch motor on when motor has cooled down sufficiently, usually within a few minutes.

 **WARNING: Automatic reset thermal overloads will allow the pump to restart without warning. ALWAYS disconnect the pump motor from the electrical supply before maintenance or repairs.**

- Note:
1. Long extension leads should be avoided as they often have insufficient current carrying capacity to run electric motors, hence they can cause substantial voltage drop and operating problems.
 2. Minimum voltage at the electric motor must not fall below 216.
 3. If the electrical fittings in your country make it necessary to remove the plug from the lead fixed to the motor care should be taken to ensure that the earth conductor green/yellow in the lead is properly connected to a good earth. This work must only be undertaken by an authorised electrician.

Three Phase

Some HM models are also available as 3 phase model for 50Hz, nominal 415volt power supply. A recommended wiring diagram can be found inside the capacitor cover (see figure one below). Three phase units must be wired in by an authorised electrician in conjunction with a contactor which has "quicktrip" (M10) overloads set at nameplate current.

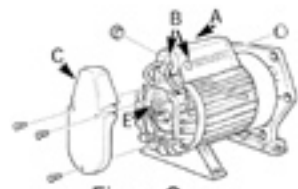

Figure One

Davey recommend the use of overloads which also have the ability to detect "single phasing" or "dropped phase" conditions in the power supply.

Three phase models with output power of below 1.4kW have been designed to provide cable entry on the right hand side when viewed from the non-drive or fan end of the motor. A terminal block is provided under the capacitor cover. Note: Three phase motors do not have capacitors fitted in the capacitor cover.

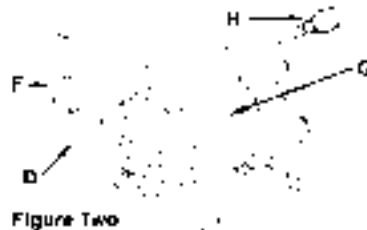

Figure Two

Access to the terminal block is achieved by removal of the fan cowl - see Figure A. Before prising the fan cowl ensure the retaining screw has been removed.



Figure A

The capacitor cover screw is then removed, allowing the cover to be lifted (Figure B). Once the wiring has been completed and checked, ensure the supply cable is run along the cable access, the capacitor cover will clamp the supply cable once it is re-installed. Replace the fan cowl and ensure the fan cowl retaining screw is re-installed correctly.

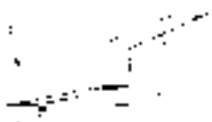

Figure B

 **WARNING: DO NOT RUN DRY. DO NOT RUN WITH LOSS OF PRIME. DO NOT PUMP WATER CONTAINING ABRASIVE MATERIALS.**

Trouble Shooting Check List

MOTOR OPERATING BUT NOT PUMPING

1. Suction line and pump body not filled with water.
2. Leaking foot valve.
3. Air leaks in suction lines or suction pipe not under water.
4. Air trapped in suction lines (also possible with flooded suction) due to uneven rise in piping (eliminate humps and hollows).
5. No water at source or water level too low.
6. Valve on suction or delivery lines closed.

MOTOR NOT RUNNING

1. Power not connected.
2. Supply voltage too low.
3. Overload tripped.
4. Motor not free to turn e.g. a blocked impeller.
5. Internal motor fault.

MOTOR RUNS FOR SOME TIME THEN STOPS - RESTARTS AUTOMATICALLY AFTER SHORT TIME

- Overload tripping in motor
- low voltage at motor terminals
 - motor in direct sunshine or in "hot box"
 - motor not free to turn (eg: blocked)

Priming and Operation

The pump body and suction line should be filled by pouring water into the priming plug hole adjacent to the outlet. Screw on the priming plug, close the discharge valve two thirds and switch pump on. Gradually open the discharge valve and the pipeline fills.

In high suction lift conditions, the pump may make a noise similar to it pumping sand or gravel; this will usually be cavitation occurring. Reduce flow until the cavitation noise stops. Once the discharge pipeline fills you can open the valve. If the cavitation noise returns, close the discharge valve slightly until it stops.

In the case of installations where there is a positive suction pressure (flooded suction) remove the pump's priming plug and slowly open the gate valve in the suction piping to allow water to enter the pump from the suction line until all air is expelled. Replace the priming plug and fully open the gate valve in the suction line and switch the pump on.

Prime should be established almost immediately, however, it may be necessary to re-prime several times on some installations before fully established optimum pump performance is obtained.

 **Do not run pump dry or allow to run continuously in a loss of prime condition. If this pump is allowed to pump water containing sand or other abrasive material, the effective life of the pump will be shortened.**

If pump runs but will not pump water, check for the following:

1. Suction line and pump body not filled with water.
2. Leaking foot valve.
3. Air leaks in suction lines.
4. Air trapped in suction line (even on flooded suction) possibly when there is an uneven rise in the piping from water to pump (eliminate "humps and hollows")

1. Ensure outlet nearest to pump is open.



3. Switch on.

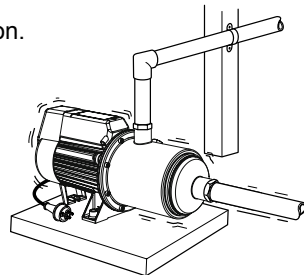

2. Fill pump body and suction line through priming plug hole located above suction inlet and replace plug.

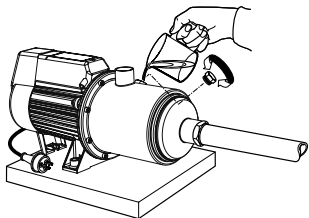

4. Prime should establish almost immediately with a strong flow of water, however, in some installations it may be necessary to repeat the above operation to remove all air from the system.

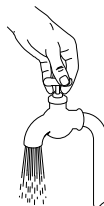

Three phase models with output power of 1.4kW and over have been designed to allow for connection either side of the Capacitor Cover (marked "A" in figure one) on the motor. (NOTE: Three phase motors do not have capacitors fitted in the Capacitor Cover).

This is achieved by way of either of the two 19mm access holes (marked "B" in figure one). The access holes are designed to accept most standard cable grommets. The unused hole can be sealed by inserting the plug enclosed with the pump. To connect a three phase Pressure Pump start by removing the Terminal Cover ("C")

In accordance with AS 3350.2.41 we are obliged to inform you that this pump is not to be used by children or infirm persons and must not be used as a toy by children.

A short four core flex ("D") is fitted from the motor terminals ("E"). This lead is inserted through the blanking grommet ("F").

Pressure switch or other control leads ("G") can be fitted as well. Incoming power ("H") can be fitted through the preferred access hole, and terminated as shown in Figure Three. A termination kit is available if required.



Insert the blanking grommet ("F") into the capacitor cover ("A"). Fix the short lead ("D") into the path provided in the non-drive endshield and replace the terminal cover ("C").

Figure Three

IMPORTANT NOTE: THREE PHASE MODELS ONLY

 **Before finalising wiring connections, check that motor rotates in direction of arrow (clockwise when shaft is viewed from wiring connection end except HM270 models which rotate anti-clockwise). To alter rotation, change any two power leads at motor terminals.**

When the unit is connected and operating the phase balance should be checked. This should be within 5% variation. "Rolling" the leads may help to improve a small unbalance, but major phase unbalance will usually be attributed to an input power unbalance. This must be addressed before the pump is used.

 **Power connections and wiring must be carried out by an Authorised Electrician.**

 **Note: Minimum three phase voltage supply at the motor must not fall below 374 volts, otherwise motor damage may result which is not claimable under Guarantee.**

 **WARNING: Some insects, such as small ants, find electrical devices attractive for various reasons. If your pump enclosure is susceptible to insect infestation you should implement a suitable pest control plan.**

IP55 Compliant Connection

For some installations, such as wet areas in dairies, the pump is required to be IP55 compliant. The HM pump is IP55 compliant (models over 1.05kW are IP56).

Pipe Connections



DO NOT USE THREAD SEALING COMPOUNDS, HEMP OR PIPE DOPE!

For best performance use P.V.C. or polythene pipe at least the same diameter as the pump's inlet. Larger diameter pipe may be used to minimise resistance to flow when pumping longer distances.

Use unions at pipe connections to enable easy removal and servicing. Use sufficient tape to ensure airtight seal and hand tighten only, do not screw connections all the way into suction port. To prevent strain on pump thread always support heavy inlet and outlet pipes. Lay suction pipe at a constant gradient to avoid air pockets which may reduce pump efficiency.

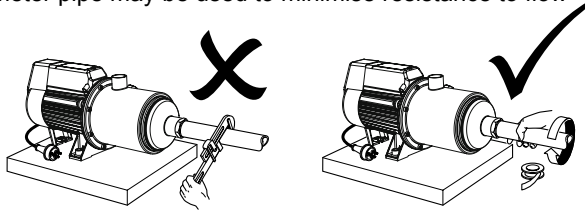

NOTE: Suction leaks are the largest cause of poor pump performance and are difficult to detect. Ensure all connections are completely sealed using thread tape only. DO NOT USE SEALING COMPOUNDS OR PIPE DOPE.

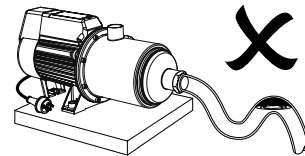

Connection to your Water Source ABOVE GROUND WATER SOURCES

Installations with flooded suction require a gate valve so water supply can be turned off for pump removal and servicing.

Install a one-way check valve in the suction pipeline to avoid water draining back past the pump while not in operation and causing possible pump damage.

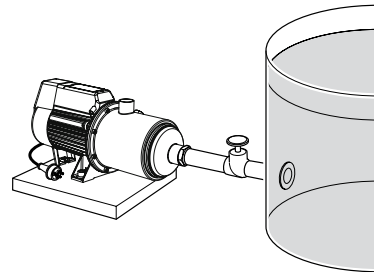

BELOW GROUND WATER SOURCES



NOTE: HM models require a foot valve or check valve to be installed in the suction pipework in suction lift applications as appropriate.

Whenever the installation position of the pump is higher than the lowest water level, a foot valve fitted to the end of the suction pipe as illustrated in (A) below is required. Ensure that the foot valve is at least 1/2 metre below minimum water level.

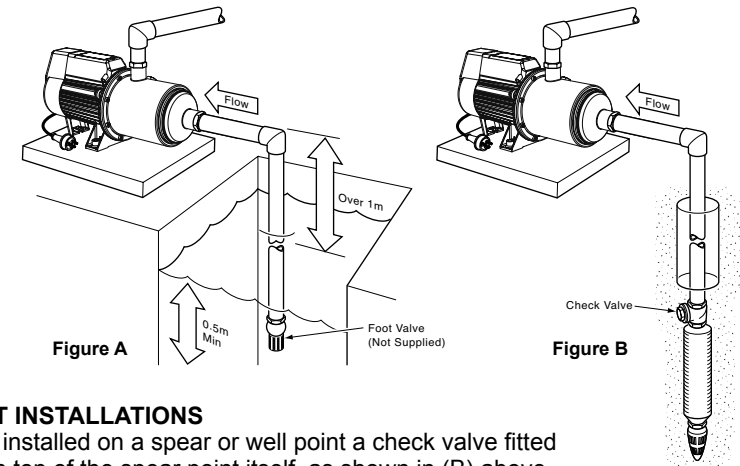

Figure A

Figure B

SPEAR POINT INSTALLATIONS

When a HM is installed on a spear or well point a check valve fitted immediately on top of the spear point itself, as shown in (B) above.



NOTE: DO NOT install the check valve at the pump or at the top of the well. DO NOT run the pump without water.



NOTE: Be certain to select the spear point to suit the well conditions and regulate the flow rate from the pump accordingly.

Spear Size	Mesh	Approx. Max. Capacity of Spear Point	
1 1/4" (32mm)	60	15 - 23 l/min	or 200 - 300 gal/hr
1 1/2" (38mm)	60	23 - 38 l/min	or 300 - 500 gal/hr
2" (50mm)	60	38 - 75 l/min	or 500 - 1000 gal/hr

Dry-running protection

To avoid accidental loss of prime of the pump, we recommend protecting it with a suitable device. Note: damage from dry-running is not covered by guarantee.

Connection of Mains Scheme or Town Water Supply to either Suction or Discharge of Pumps

Most Water Supply Authorities have strict regulations regarding direct connection of pumps to mains water supplies. In most cases an isolating tank is required between mains supply and pump. Davey also recommend this method. Directly applied mains pressure can exceed pump operating pressure and damage pump.

Davey Water Products Pty Ltd can not accept responsibility for loss or damage resulting from incorrect or unauthorised installations.

