

DAVEY KINETICO SOFTENER
Model Number: Mach 2020cHF

DEPEND ON
DAVEY

WATER PRODUCTS



WATER SOFTENERS

PRODUCT DESCRIPTION

High performance non-electric counter current water softeners

APPLICATIONS

Davey Kinetico softeners are ideal for reducing calcium and magnesium from water sources.

Hard water can mean hard work.... hard work in the kitchen, laundry & bathroom. Davey's Kinetico water softeners offer a hard working alternative to make your life easier by dependably providing soft clean water.

FEATURES & BENEFITS



Non Electric

Only Davey Kinetico uses the kinetic energy of moving water to power its system instead of electricity – thanks to the patented turbine. So you'll never have to worry about costly repairs or higher electricity bills.



24/7

Our twin tank design allows our system to backwash without ever going offline for round the clock operation. You'll never be interrupted or inconvenienced by regeneration.



Metered Regeneration

Measures water use to accurately determine when it's time to regenerate with clock like precision, resulting in up to 20% less waste water and up to 40% savings in salt. Your softener automatically adjusts to your water use patterns.



Soft Water Rinse

Uses only soft conditioned water to clean the media, which extends the life of the system.



Counter Current Regeneration

Unlike most other systems, ours regenerates in counter-current mode, a more even and efficient use of resin beads, resulting in less waste water, less salt use and a longer lasting system.

OPERATING LIMITS

Inlet Water Quality

Pressure Range	1.0-8.6 Bar
Temperature Range	2 - 49°C
pH Range	5 – 10 SU
Free Chlorine Cl ₂ (Max.)	2.0mg/l
Hardness as CaCO ₃ (Max.)	342mg/l
Iron	<0.1mg/l

Operating Specs

Flow Range (1.0 – 2.1 Bar)	32 - 51 lpm
Flow Configuration	Alternating
Dimensions (w x d x h)	210 x 457 x 483mm
Weight (operating / Shipping)	38.6 / 20.4kg



TECHNICAL SPECIFICATIONS

SYSTEM COMPONENTS

Media Vessel (qty) Size	(2) 152 x 330mm
Media Vessel Construction	Fiberglass Wrapped Engineered Plastic
Empty Bed Volume	4.5 litres
Media Type	Uniform Bead Cation Resin
Media Volume	4.5 litres
Bed Depth	330mm
Free Board	0mm
Riser Tube	25mm ABS
Distributor Upper	0.23mm Slots, GFN Basket
Lower	0.23mm Slots, Stainless Steel Flat Plate
Under bedding	None
Regeneration Control	Non-electric Use Meter
Regeneration Type	Countercurrent
Meter Type	0.2-26.5 lpm Polypropylene Turbine

CONNECTIONS

Inlet / Outlet Connections	25mm Custom Adapter and Bracket
Drain Connection	13mm Tube
Brine Line Connection	10mm Tube
Power	None

BRINE TANK OPTIONS

Tank Description	incorporated into unit
Brine Tank Part Number	N/A
Tank Height	483mm
Tank Footprint	457 x 229mm
Material	ABS
Salt Capacity	10.0kg

REGENERATION SPECIFICATIONS

Regeneration Volume	19 Litres
Regeneration Time	11 minutes
Backwash Flow Control	2.6 lpm
Brine Refill Flow Control	1.1 lpm

Operating Profile

Softener shall remove hardness to less than 9 mg/l when operated in accordance with the operating instructions. The system shall include two tanks. This duplex configuration shall operate with one tank on-line during service. During regeneration cycles, one tank shall provide water to service and to the regenerating tank. A water meter shall initiate system regeneration. The water meter shall measure the processed volume and be adjustable. Service flow shall be down-flow and regeneration flow shall be up-flow.

Regeneration Control Valve

The regeneration control valve shall be top mounted (top of media tank), and manufactured from non-corrosive materials. Control valve shall provide service and regeneration control for two media tanks. Inlet and outlet ports shall accept a quick connect, double o-ring sealed adapter. Interconnection between tanks shall be made through the regeneration valve with a quick connect adapter. Control valve shall operate using a minimum inlet pressure of 1 Bar. Pressure shall be used to drive all valve functions. No electric hook-up shall be required. Control valve shall incorporate four operational cycles including; service, brine draw, slow rinse, and a combined fast rinse and brine refill. Service cycle shall operate in an up-flow direction. The brine cycle shall flow down-flow, opposite the service flow, providing a countercurrent regeneration. Control valve shall contain a fixed orifice provider nozzle and self-adjusting backwash flow control. The control valve will prevent the bypass of hard water to service during the regeneration cycle.

Media Tanks

The tanks shall be designed for a maximum working pressure of 8.6 Bar and hydrostatically tested at 20.7 Bar. Tanks shall be made of engineered plastic with a 63.5mm. threaded top opening. Each tank shall be NSF approved. Upper distribution system shall be of a slot design. Lower distribution system shall be of a flat plate design. Distributors will provide even flow of regeneration water and the collection of processed water.

Conditioning Media

Each softener shall include uniform bead cation resin having a minimum exchange capacity of 18 g/l when regenerated with 240.3g/l. The media shall be solid, of a proper particle size and shall contain no plates, shells, agglomerates or other shapes, which might interfere with the normal function of the water softener.

Brine System

A combination salt storage and brine production tank shall be manufactured of corrosion resistant, plastic. The brine tank shall have a chamber to house the brine valve assembly. The brine float assembly shall allow for adjustable salt settings and shall provide for a shut-off to the brine refill. The brine tank shall include a safety overflow connection to be plumbed to a suitable drain.

DIMENSIONS

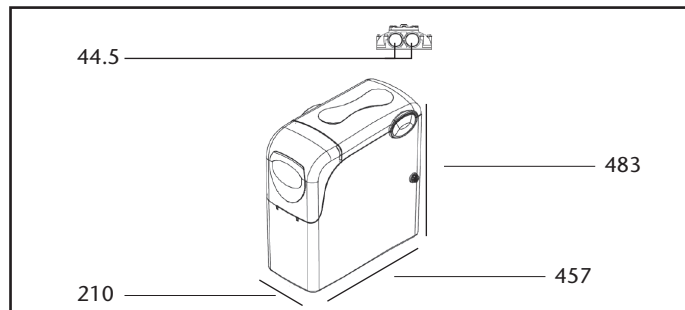

All dimensions in mm unless otherwise stated.

DISC SELECTION (Compensated hardness**) – Disc 4 Fitted

Regeneration setting	Hardness Capacity	Efficiency	Dosing	Meter Disc	1	2	3	4	5	6	7	8
0.22kg*	90g	400g/Kg	50g/L		34	68	86	120	154	188	222	257
0.34kg*	121g	360g/Kg	75g/L		34	86	120	171	222	257	308	342
		Litres processed before regeneration			2,207	1,105	734	553	443	367	314	276

*Certified by NSF and/or WQA **Compensated hardness in mg/L = (Hardness + 51 x Fe in mg/L)

NOTE: THIS MODEL NOT SUITABLE FOR SUPPLY TO STORAGE OR USE WITH IRON BEARING WATER, USE ON MUNICIPAL MAINS PRESSURE SUPPLIES ONLY

This literature is not a complete guide to product usage. Further information is available from your Davey dealer, Davey Customer Service Centre and from the relevant product Installation and Operating Instructions. This data sheet must be read in conjunction with the relevant product Installation and Operating Instructions and all applicable statutory requirements. Product specifications may change without notice.

© Davey is a registered trademark of Davey Water Products Pty Ltd. © Davey Water Products Pty Ltd 2008.



Visit Davey on-line for further information
davey.com.au

DEPEND ON
DAVEY

WATER PRODUCTS

Davey Water Products Pty Ltd

Member of the GUD Group
ABN 18 066 327 517

Head Office and Manufacturing

6 Lakeview Drive,
 Scoresby, Australia 3179
 Ph: +61 3 9730 9222
 Fax: +61 3 9753 4100
 Website: davey.com.au

Customer Service Centre

Ph: 1300 2 DAVEY (1300 232 839)
 Fax: 1300 304 850
 E-mail: sales@davey.com.au

Interstate Offices

Sydney • Brisbane • Adelaide
 Perth • Townsville

International

6 Lakeview Drive,
 Scoresby, Australia 3179
 Ph: +61 3 9730 9121
 Fax: +61 3 9753 4248
 E-mail: export@davey.com.au

USA

Website: daveyusa.com
 E-mail: sales@daveyusa.com

Davey Water Products – New Zealand

7 Rockridge Avenue,
 Penrose, Auckland 1061
 Ph: +64 9 570 9135
 Fax: +64 9 527 7654
 Website: daveynz.co.nz
 E-mail: sales@daveynz.co.nz

Davey Spa – New Zealand

2 Rothwell Avenue,
 North Harbour, Auckland 0632
 Ph: +64 9 415 8622
 Fax: +64 9 415 8621
 Website: spa-quip.co.nz
 E-mail: service@spa-quip.co.nz