

DAVEY WATER PRODUCTS GUARANTEE FOR AUSTRALIA & NEW ZEALAND

Davey HP Pressure systems fitted with Torrium control are guaranteed for a period of two years from the date of original purchase to be free of material or manufacturing defects. Should any part fail as a result of such defects within this period, the pressure system will be repaired free of charge.

TERMS AND CONDITIONS

1. This guarantee applies to all states and territories of Australia and New Zealand only and is subject to the provisions of the Trade Practices Act (Aust.), the Goods and Consumer Protection Legislation of the various Australian states and the Consumers Guarantee Act 1993 (NZ) as applicable.
2. The guarantee period commences on the date of original purchase of the equipment. Evidence of this date of original purchase must be provided when claiming repairs under guarantee. It is recommended you retain all receipts in a safe place.
3. This guarantee covers parts and workshop labour only. Goods should be forwarded, with proof of date of original purchase, to an Authorised Davey Service Centre freight paid.
4. This guarantee is subject to due compliance by the original purchaser with all directions and conditions set out in the Installation and Operating Instructions. Failure to comply with these instructions, damage or breakdown caused by fair wear and tear, negligence, misuse, incorrect installation, chemical or additives in the water, inadequate protection against freezing, rain or other adverse weather conditions, corrosive or abrasive water, lightning or high voltage spikes or through unauthorised persons attempting repairs are not covered under guarantee. The product must only be connected to the voltage shown on the nameplate.
5. Without limiting the original purchaser's entitlements under the Trade Practices Act (Aust.), the Goods & Consumer Protection Legislation of the various Australian states, or the Consumers Guarantee Act 1993 (NZ), Davey shall not be liable for any loss of profits or any consequential, indirect or special loss, damage or injury of any kind whatsoever arising directly or indirectly from the product or any defect.
6. Where the Trade Practices Act (Aust.), the Goods and Consumer Protection Legislation of the various Australian states and the Consumers Guarantee Act 1993 (NZ) does not apply, Davey shall not be liable for any loss of profits or any consequential, indirect or special loss, damage or injury of any kind whatsoever suffered by the purchaser arising directly or indirectly from the product or any defect and the purchaser shall indemnify Davey against any claim by any other person whatsoever in respect of any such loss, damage or injury.
7. Nothing in this guarantee is intended to have the effect of contracting out of the provisions of the Trade Practices Act (Aust.), the Goods and Consumer Protection Legislation of the various Australian states and Consumers Guarantee Act 1993 (NZ) except to the extent permitted by the various Acts and this guarantee is to be modified to the extent necessary to give effect to that intention.
8. Davey may be collecting personal information from you in order to provide you with a service. Davey Pumps Pty Ltd promises only to use this information in accordance with the Provisions of the Privacy Act 1988 (Cth) and the Privacy Policy of Davey Pumps Pty Ltd which is available at www.davey.com.au.

© Davey and Torrium are registered trademarks of Davey Water Products Pty Ltd. © Davey Water Products Pty Ltd 2002.

Davey Water Products Pty Ltd

Member of the GUD Group
ABN 18 066 327 517

Head Office and Manufacturing

6 Lakeview Drive,
Scoresby, Australia 3179
Ph: +61 3 9730 9222
Fax: +61 3 9753 4100
Website: davey.com.au

Customer Service Centre

Ph: 1300 367 866
Fax: 1300 369 119
E-mail: sales@davey.com.au

Interstate Offices

Sydney • Brisbane • Adelaide
Perth • Townsville

International

6 Lakeview Drive,
Scoresby, Australia 3179
Ph: +61 3 9730 9121
Fax: +61 3 9753 4248
E-mail: export@davey.com.au

Germany

Kantstrasse 53,
04275 Leipzig
Ph: +49 341 301 0412
Fax: +49 341 301 0413
E-mail: akrenz@daveyeurope.com

New Zealand

7 Rockridge Avenue,
Penrose, Auckland 1330
Ph: +64 9 570 9135
Fax: +64 9 527 7654
Website: daveynz.co.nz
E-mail: sales@daveynz.co.nz

USA

Davey Pumps Inc.
1005 N. Commons Drive
Aurora, Illinois 60504
Ph: +1 630 898 6976
Fax: +1 630 851 7744
Website: daveyusa.com
E-mail: sales@daveyusa.com

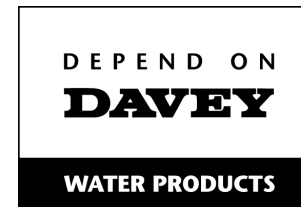

Installation and Operating Instructions for Davey XP/T & XJ/T Pressure Systems with

DAVEY torrium



NOTE: Prior to installation remove the red transport plugs & associated seals from the suction and/or discharge ports.



WARNING: The Torrium® controller, pump and associated pipework operate under pressure. Under no circumstances should the Torrium® controller, pump or associated pipework be disassembled unless the internal pressure of the unit has been relieved. Failure to observe this warning will expose persons to the possibility of personal injury and may also result in damage to the pump, pipework or other property.



WARNING: Failure to follow these instructions and comply with all applicable codes may cause serious bodily injury and/or property damage.

Please pass these instructions on to the operator of this equipment.

P/N 400280-6 supersedes P/N 400280-5

Prior to using this pump you must ensure that:

- The pump is installed in a safe and dry environment
- The pump enclosure has adequate drainage in the event of leakage
- Any transport plugs are removed
- The pipe-work is correctly sealed and supported
- The pump is primed correctly
- The power supply is correctly connected
- All steps have been taken for safe operation

Appropriate details for all of these items are contained in the following Installation and Operating Instructions. Read these in their entirety before switching on this pump. If you are uncertain as to any of these Installation and Operating Instructions please contact your Davey dealer or the appropriate Davey office as listed on the back of this document.

Congratulations on your purchase of a high quality, Australian built Davey pressure system. All components have been designed and manufactured to give trouble free, reliable operation.

Your new pressure system incorporates 'Torrium®', electronic flow controller – a Davey designed unit that enables the use of a highly efficient pump design and offers the following benefits:–

1. Enables the pump to deliver a constant flow of water particularly at low flow rates – reducing the inconvenience of pressure variation in showers etc.
2. Provides automatic “cut-out” protection should the pump run out of water or overheat*, should the pump fail to start due to low voltage or a blockage in the pump.
3. Provides warning indications for critical and noncritical system faults.
4. Has adaptive pressure cut-in which allows the pump to start at approximately 80% of the maximum pressure at last shut-down. This allows the controller to accommodate varying inlet pressures and pump performance.
5. Automatic retry functions in the event of a critical system fault.

* Motor overload / overheat protection included. Motor has its own overload / overheat protection.

Before installing your new pump, please read all instructions carefully as failures caused by incorrect installation or operation are not covered by the guarantee. Your Davey pressure system is designed to handle clean water. The system should not be used for any other purpose without specific referral to Davey. The use of the system to pump flammable, corrosive and other materials of a hazardous nature is specifically excluded.

NOTE: Prior to installation remove the red transport plugs from the suction and/or discharge.



NOTE:

- a) For protection, the Davey® pump motor is fitted with an automatic “over temperature” cut-out. Constant tripping of this overload device indicates a problem e.g. low voltage at pump, excessive ambient temperature (above 50°C) in pump enclosure.
- b) The Torrium® control device may have to be reset after rectifying any of the above operating troubles. This is done by pushing in the “prime” button and releasing it after 2 seconds, or switching the power supply off then on.



WARNING: When servicing or attending pump, always ensure power is switched off and lead unplugged. Electrical connections should be serviced only by qualified persons. If the electrical supply lead of this pressure system is damaged, it must be replaced.



Care should also be taken when servicing or disassembling pump to avoid possible injury from pressurised water. Unplug pump, relieve pressure by opening a tap on the discharge side of the pump and allow any hot water in the pump to cool before attempting to dismantle.



During servicing, use only approved, non-petrochemical based oring and gasket lubrication. If unsure, consult your Davey Dealer for advice.



WARNING: Do not use hydrocarbon based or hydrocarbon propelled sprays around the electrical components of this pump.

After Sales Service

For professional after sales service or repair contact your Davey Dealer. For assistance in locating your nearest dealer contact the Davey Customer Service Centre on 1300 367 866 or the appropriate branch as listed on the back of this document.



Visit Davey Water Products on-line for further information

davey.com.au

d) MOTOR STOPS - STATUS INDICATOR LIGHT IS ILLUMINATED RED, FLASHING TWICE PER SEQUENCE

1. Motor "over temperature" cut-out tripped. Consult Davey dealer.
2. Motor not free to turn - e.g. a jammed impeller. Consult Davey dealer.
3. Prime button has been held in for too long. Release prime button and switch off power for 1 minute to allow unit to reset.

e) PUMP WILL NOT STOP

1. Water leaks on discharge side of pump.

f) PUMP WILL OPERATE NORMALLY INITIALLY BUT WILL NOT RESTART ON WATER DEMAND - STATUS INDICATOR LIGHT NOT ILLUMINATED

1. Power supply problem - see c) 1.

g) PUMP WILL OPERATE NORMALLY INITIALLY BUT WILL NOT RESTART ON WATER DEMAND - STATUS INDICATOR LIGHT IS ILLUMINATED RED CONSTANT

1. Suction air leak - pump has partially lost prime.
2. Blocked impellers or suction.
3. Discharge valve closed - open valve.

h) PUMP HAS OPERATED NORMALLY FOR SOME TIME, BUT NOW WILL NOT RESTART OR THE PRESSURE DROPS TO A LOWER POINT BEFORE THE PUMP STARTS - STATUS INDICATOR LIGHT IS ILLUMINATED WITH THREE FLASHES PER SEQUENCE

1. Your Torrium® has detected a slow leak and has dropped the cut-in pressure to a lower cut-in pressure to help reduce the pump cycling. Correct the leak, and your Torrium will return to normal operation automatically or cycle power for immediate return to normal.



NOTE: The Torrium® controller fitted to this pump is adaptive. If your pump draws air or is subject to blockage, the Torrium adapts to its new maximum pressure. This may result in your system pressure not dropping below the new cut-in pressure and your pump not starting. Should this occur, re-prime your pump units as detailed above. Should this not prove successful, it is likely you have a blockage in the pump. You should contact your Davey dealer for assistance.

i) PUMP HAS STOPPED OPERATING - STATUS INDICATOR LIGHT IS ILLUMINATED RED FLASHING THREE TIMES PER SEQUENCE.

1. Your Torrium® has detected high water temperature in the pump. Once the water has cooled the Torrium will automatically restart the pump.

j) PUMP IS OPERATING NORMALLY, BUT THE STATUS INDICATOR LIGHT IS ILLUMINATED FLASHING TWICE PER SEQUENCES - RED FLASHES WHILE IN STANDBY OR AMBER FLASHES WITH CONSTANT GREEN WHILE PUMP RUNNING

1. Your Torrium® has detected low voltage (below 180 volts for >10 seconds). The low voltage may result in a small pump performance shortfall. Once the voltage has returned to normal the status indicator will return to normal.



1. Torrium® Priming Plug
2. Torrium® Control Module (T45 except XJ70T which uses T70)
3. Discharge Outlet (1" BSPM)
4. Suction Inlet (1 1/4" BSPF, except XP350T which is 1" BSPF)
5. Pump Body
6. Motor
7. Locking Nut
8. Priming Plug

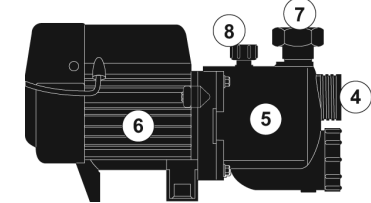
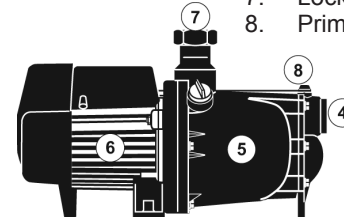
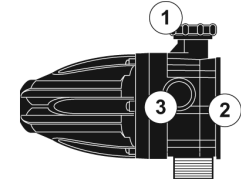

Preparing Your System

On removing your pressure system from its carton you will need to position the Torrium® control module on top of the pump. Once in position on top of the pump hand tighten the locking nut. The Torrium® unit is capable of 360° rotation to enable the most convenient positioning of the discharge piping. Loosening the locking nut enables convenient adjustment.

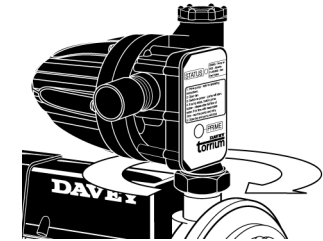

Only connect the discharge pipework to the discharge port. The priming port is not a discharge port.

Choosing a Site

Choose a site with a firm base and as close to the water source as possible with correct power supply. Make sure your pressure system is always connected to an adequate, reliable source of clean water.

Housing your Davey Pressure System

To protect your pressure system from the weather, make sure the pump house is both water proof, frost free and has adequate ventilation. The pump should be horizontally mounted on a firm base allowing for drainage, to avoid damage to flooring etc., that over time may occur from leaking pipe joints or pump seals. Do not mount the pump vertically.

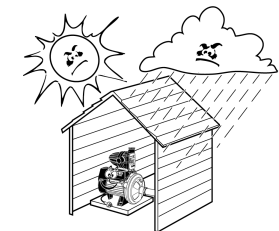

WARNING: Some insects, such as small ants, find electrical devices attractive for various reasons. If your pump enclosure is susceptible to insect infestation you should implement a suitable pest control plan.

Power Connection

Connect lead to power supply designated on pump label. Do not use long extension leads as they cause substantial voltage drop, poor pump performance and may cause motor overload.



The Davey Torrium® fitted to this pump has a **status indicator light** mounted on its front panel. This light will be illuminated whenever the Torrium® senses that there is electrical power available. The light will only work when unit is connected to the correct electrical supply.



The electrical connections and checks must be made by a qualified electrician and comply with applicable local standards.

Status Indicator

The Torrium® has a status indicator light on the front panel. This light will enable you to understand what your pump is doing.

Condition	Indicator readout	Pump operation	Restart / Reset Method
Standby mode	Red light	Standby	Pressure drop
Running	Green light	Running	N/A
Cistern fill	Yellow/Amber light	Running - 2 minutes minimum run time	Auto, push "Prime" button or cycle power off / on
Loss of Prime	Red light single flash	Stops, auto-retry & "water return" activated	Push "Prime" button or cycle power off / on
Locked rotor or 'Prime' button held in too long	Red light double flash	Stops	See Trouble shooting guide
Undervoltage	Red light double flash	Normal operation	Wait till voltage >180 volts or push "Prime" button or cycle power off / on
Water over temperature	Red light triple flash	Stops	Wait till water temp < 60°C
Slow leak	Red light triple flash	Normal operation with reduced cut-in pressure	Auto-reset or push "Prime" button or cycle power off / on

Both the Red & Green Indicators are shown in the same window. It is possible for the pump to be running (ie. Green indicator) and for a Red flash sequence to happen at the same time. In that case the Red flash will show as a Yellow or Amber flash.



Only one fault condition will be indicated at once.

Cistern Fill Mode

When your new XP or XJ pressure system is used to fill toilet cisterns or troughs, a special feature of the Torrium® controller may be activated. This special feature is activated when the controller detects three quick stop start sequences in a short period. When activated the status indicator will glow "Amber", and the pump will run on for two minutes before shutting down. This allows the cistern to be filled with the minimum number of pump cycles.

Maintenance



WARNING : Under no circumstances should Torrium® controller be disassembled. Failure to observe this warning will expose persons to the possibility of personal injury and may also result in damage to other property. Do not dismantle, no user serviceable parts, spring under pressure.

The only regular attention your new pressure system may require will be if you have used an additional pressure tank. You will need to check the pressure tank's air charge every 6 months. This can be checked at the air valve with a tyre gauge. Do not charge tank to a higher pressure than that shown in the table on page 6.

To check air pressure in tank:

1. Switch off pump.
2. Open outlet nearest to pump to release water pressure.
3. Charge tank to required pressure using air pump and check with tyre gauge.
4. Switch on.
5. Close outlet.



WARNING: Automatic reset thermal overloads may allow the pump to restart without warning. Always disconnect the pump motor from the electrical supply before maintenance or repairs.



WARNING: When servicing or attending pump and/or controllers, always ensure power is switched off and lead unplugged. Electrical connections should be serviced only by qualified persons.

Trouble Shooting Check List

- PUMP HAS STOPPED OR MOTOR RUNS FOR SHORT PERIOD ONLY WHEN SWITCHED ON OR PRIME BUTTON PUSHED, BUT DOES NOT PUMP - STATUS INDICATOR LIGHT ILLUMINATED RED FLASHING ONCE PER SEQUENCE**
 1. Suction line and pump body not filled with water.
 2. Air leaks in suction lines or suction pipe not under water.
 3. Air trapped in suction lines (also possible with flooded suction due to uneven rise in piping; eliminate humps and hollows).
 4. No water at source or water level too low.
 5. Valve on suction lines closed. Open valve & pump will restart automatically or press "Prime" button.
- PUMP SWITCHES ON AND OFF FREQUENTLY (CYCLING)**
 1. Cycling may occasionally be caused by float valves filling tanks - see "Cistern Fill Mode".
 2. Leaking taps, float valves etc. check plumbing.
 3. Leaking check valve/foot valve.
 4. Discharge plumbing has been connected to the priming port.
- MOTOR DOESN'T START WHEN SWITCHED ON - LOW PRESSURE INDICATOR LIGHT NOT ILLUMINATED**
 1. Power not connected or no power available from supply outlet.

Connection of Mains Scheme or Town Water Supply to either Suction or Discharge of Pumps & Pressure Systems

Most Water Supply Authorities have strict regulations regarding direct connection of pumps to mains water supplies. In most cases an isolating tank is required between mains supply and pump. Davey also recommend this method. Directly applied mains pressure can exceed pump operating pressure and damage pump.

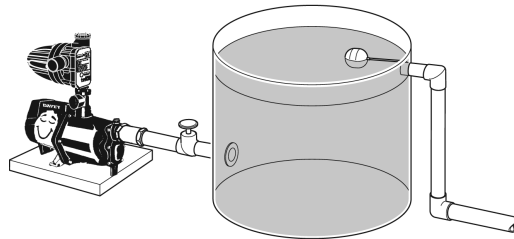

Davey Water Products Pty Ltd can not accept responsibility for loss or damage resulting from incorrect or unauthorised installations.

Priming and Operation

The Torrium® module fitted to your XP or XJ system is provided with a push button "Prime" button. This button is used during initial priming of the pump and also acts as a reset button if the Torrium® switches out in pump protection mode.

1. Remove priming plug and fill casing and suction line (on flooded suction, simply open gate valve to pump). When full, replace priming plug.

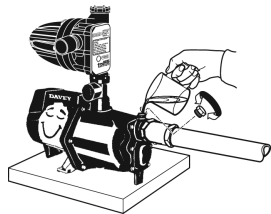

2. Ensure outlet nearest to pump is open.



3. Ensure all valves in suction line are open.

4. Switch on power - The status indicator light will be illuminated green and the pump will run. A full flow of water should be discharged from the open tap.



5. If the pump stops with the tap open see troubleshooting checklist.

6. Close the open outlet or tap and the pump should stop after a few seconds (the status indicator light should be illuminated red (constant). If not, consult the troubleshooting checklist.

To Reset if Pump switches out in Pump Protection Mode

1. Make sure pump is primed.
2. Open tap, push prime button.
3. Close tap and pump will stop.

8

Auto-retry and Water Return Modes

Should your Torrium® detect a loss of prime, after stopping the pump, it will wait five minutes before activating Auto-retry and Water Return modes. Auto-retry automatically starts the pump to see if the pump is now primed. It does this after 5 mins, 30 mins, 1 hr, 2 hrs, 8 hrs, 16 hrs and 32 hrs. Water return mode will restart the pump automatically if the Torrium® detects water flow through it.



NOTE: If multiple errors are present, the highest priority error (least number of flashes) is indicated. Any previous fault code is lost until it recurs.

Electrical Power Surge Protection

An electrical power surge or spike can travel on the supply lines and cause serious damage to your electrical equipment. The Torrium® fitted to this pump has a metal oxide varistor (MOV) fitted to help protect it's circuit. This MOV is a "sacrificial" device, meaning that it effectively is gradually damaged every time it takes a surge. The MOV is not a lightning arrester and may not protect the Torrium® if lightning or a very powerful surge hits the pump unit.

If the installation is subject to electrical power surges or lightning we strongly recommend the use of suitable additional surge protection devices on ALL electrical equipment.

In accordance with AS 3350.2.41 we are obliged to inform you that this pump is not to be used by children or infirm persons and must not be used as a toy by children.



NOTE: For protection, the Davey pump motors are fitted with an automatic reset thermal overload, constant tripping of this overload indicates a problem e.g. low voltage at pump, excessive temperature (above 50°C) in pump enclosure.

Pipe Connections

For best performance use P.V.C. or polythene pipes at least the same diameter as the pump's inlet and delivery outlet openings. Larger diameter pipe may be used to minimise resistance to flow when pumping longer distances.

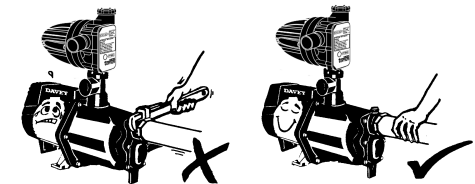

Do not use pipe thread sealing compounds on any part of this pump. ONLY use Teflon sealing tape.

5

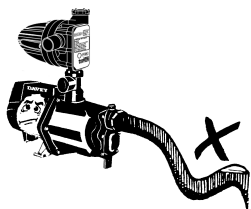

Use unions at pipe connections to enable easy removal and servicing. Use sufficient tape to ensure airtight seal and hand tighten only. To prevent strain on pump threads always support heavy inlet and outlet pipes. If there is a likelihood the water supply may contain solid particles such as pieces of plant or vegetable matter, a filter should be installed before the pump to avoid blocking of water ways.

Lay suction pipe at a constant gradient to avoid air pockets which may reduce pump efficiency.

NOTE: Suction leaks are the largest cause of poor pump performance and are difficult to detect. Ensure all connections are completely sealed using thread tape only.

Extra Draw-off Capacity

The "Torrium®" has an in-built accumulator which will accommodate small leaks. In some applications it may be appropriate to install additional accumulator (Supercell pressure tank) capacity. These applications includes:

- Long suction lines (see Suction Lines / Lift)
- Low flow appliances connected to the pump, such as evaporative air conditioners, slow filling toilet cisterns.

Any additional accumulators can be installed either in place of the priming plug (see figure one) for tanks up to 20 litres total capacity, or for larger tanks, downstream of the controller (ie. between the controller and the first outlet).

Where extra draw-off capacity is utilised the additional pressure tank should have a pre-charge as listed on the table below.

Fit the Supercell pressure tank (up to 20 litres total capacity) to the tank connection/ priming port with thread tape. Firmly hand tighten.

Pump Model	Tank pre-charge		
	Zero suction	2 metre suction	4 metre suction
XP350T	270	250	230
XJ50T	350	330	310
XJ70T	390	370	350
XJ90T	350	330	310

DO NOT USE THREAD SEALING COMPOUNDS, HEMP OR PIPE DOPE!

Where to use Check Valves and Foot Valves

The Torrium® controller fitted to your new pump has an in-built non-return (check) valve fitted. In flooded suction installations there is no need to have a suction non-return valve.

In suction lift installations a footvalve will normally be required for the pump to retain prime.

In some suction lift installations there may be good reason to remove the inbuilt check valve to ensure that the discharge pressure is also applied to the suction line and footvalve. This could be where the suction line was very long or where there was concern regarding a leaking footvalve. This may not always be applicable and it is acceptable to retain the inbuilt check valve in the Torrium on suction lifts with good suction plumbing.

Should the inbuilt check valve be removed though, an additional accumulator should be fitted to the Torrium, or discharge pipework as applicable, to ensure the pump is not cycled on shut down. The size of this accumulator will depend on the size, length and type of pipe used on the suction.

Torrium Check Valve Removal

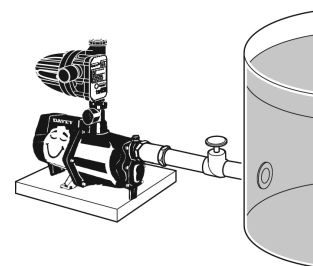
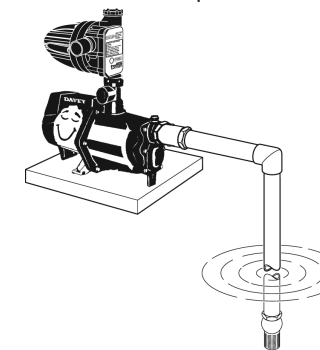
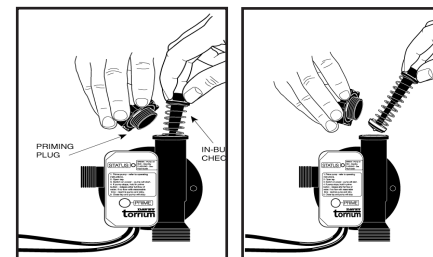

Installations with flooded suction require a gate or isolating valve so water supply can be turned off for pump removal and servicing.

Abrasive Materials
The pumping of abrasive materials will cause damage to the pressure system which will then not be covered by the guarantee.

For Automatic Pressure Pumps Installed with a Mains Pressure Hot Water System

To protect your system from damage caused by back pressure from hot water systems. You should always have installed on the hot water inlet an approved non-return valve.

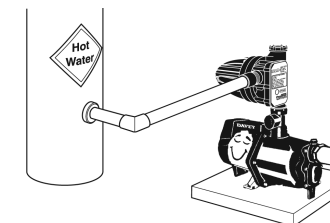

NOTE: Always ensure hot water systems are installed in compliance with manufacturers recommendations and in accordance with all local regulations.