

SINGLE IMPELLER "FIREFIGHTER®"
Model Numbers: 5155H, 5160B,
5165H & 5165HE

DEPEND ON
DAVEY

WATER PRODUCTS



SELF PRIMING PUMPS

PRODUCT DESCRIPTION

Rugged, economical single impeller self priming pump. These units are driven by either a 6hp Briggs & Stratton "Vanguard" engine, a 5.5hp Honda GX160 engine or a 6.5hp Honda GX200 engine. The GX200 engine is also available in electric start.

APPLICATIONS

- Firefighting
- Tanker to tanker water transfer
- High head general water transfer
- Sheep jetting
- Irrigation
- Boom spraying

FEATURES & BENEFITS

Patented clamped impeller design to enable longer impeller life, improved performance and easier disassembly in the case of blockage.

Single impeller design provides the versatility of high flow rates with strong pressure.

Thrust balanced impeller design to extend engine life.

Pump casing, diffusers and impellers manufactured from quality corrosion resistant marine grade aluminium for long life.

4 way discharge port for easy installation with a choice of plumbing sizes.

Polyester coated pump casing, exterior and interior, for added corrosion resistance.

Patented floating impeller neckrings front and back. The front neckring helps improve pumping efficiency, the back neckring helps extend seal life and dramatically reduce engine wear.

Self priming from 7m for more versatile installation options.

Large priming and drain port with bayonet fit plugs. Plugs have safety retention system, plus are available with 1/4" tapping to accept pressure gauges or drain cocks.

Low-oil protection on all models - engines won't start or run if oil level is inadequate, thus protecting your engine.

All engines feature cast iron cylinder bore for long life.

Electric start models have electric starter (battery and leads required) and recoil starter fitted, ensures a choice of starting methods, even if the battery is flat or removed.

Viton seal and oring kit available for herbicide/insecticide spraying.

All engines conform to the tough environmental requirements of the USA EPA and CARB standards, to help look after the environment.

OPERATING LIMITS

Flows to	500lpm
Maximum total head	72m
Maximum suction Lift	7m
Maximum water temperature	50°C
Minimum water temperature	1°C
Maximum casing pressure	1000kPa
Minimum suction pipe size	1 1/2"
Suction pipe strainer	Required
Inlet size	1 1/2" BSP(M)*
Outlet sizes	2 x 1 1/2" BSP(M)* 2 x 1" BSP(M)*

* NPT thread available on request.



TECHNICAL SPECIFICATIONS

MATERIALS OF CONSTRUCTION

PART	MATERIAL
Suction cover	Marine grade aluminium (AS605)
Diffuser	Marine grade aluminium (AS605)
Impeller	Marine grade aluminium (AS605)
Casing / yoke	Marine grade aluminium (AS605)
Mechanical seal	Carbon / ceramic
4 way discharge	Marine grade aluminium (AS605)
Casing bolts	Zinc plated steel
Yoke bolts	Stainless steel
Flap valve / seal ring	Zinc body, Hytrel seal
Neck ring, priming & drain plug	Glass filled Nylon
Casing, priming & drain plug oring	Nitrile rubber
Discharge gasket	Hytrel
Paint finish	Baked polyester powder coat

ENGINE SPECIFICATIONS

Single Stage Pump Model	5155H	5165H	5165HE	5160B
Engine Brand	Honda			B&S
Engine Model	GX160	GX200	GX200E	Vanguard
Engine Type	Overhead Valve			
Max. HP @ 3600 rpm	5.5	6.5	6.5	6.0
Displacement (cc)	163	196	196	182
Fuel Tank (litres)	3.6	3.6	3.6	4
Oil Capacity (litres)	0.6	0.6	0.6	0.7
Compression Ratio	8.5:1			
Air Filter Type	Dual stage - foam prefilter with paper element final filter			
Spark Arrestor	NO	NO	NO	YES
Approx. fuel consumption @ full load @ 3600 rpm	1.73l/hr	2.05 l/hr	2.05 l/hr	1.93 l/hr
dBa @ 4m @ 3600 rpm @ full load	85	86	86	75

INSTALLATION & PRIMING

- Fit strainer to bottom of suction pipe; a foot valve is not required
- To prime, fill pump body with water then allow pump to run until drawing water

This literature is not a complete guide to product usage. Further information is available from your Davey dealer, Davey Customer Service Centre and from the relevant product Installation and Operating Instructions. This data sheet must be read in conjunction with the relevant product Installation and Operating Instructions and all applicable statutory requirements. Product specifications may change without notice. © Davey and Firefighter are registered trademarks of Davey Products Pty Ltd. © Davey Products Pty Ltd 2004.

DEPEND ON
DAVEY

WATER PRODUCTS

HYDRAULIC PERFORMANCE

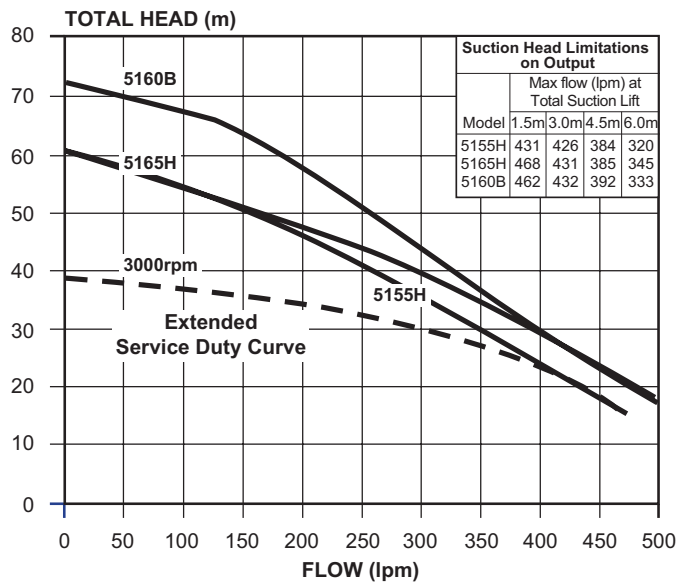

DIMENSIONS

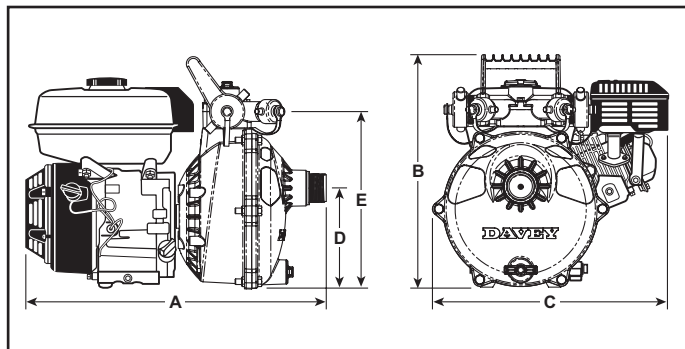

Model	A	B	C	D	E	Inlet BSP	Outlet BSP	Net Weight kg.
5165H 5165HE	510	388	402	169	296	1 1/2" M	2x1" M 2x1 1/2" M	22 22.5
5155H	445	388	388	169	296	1 1/2" M	2x1" M 2x1 1/2" M	21
5160B	535	388	395	169	296	1 1/2" M	2x1" M 2x1 1/2" M	25.5

All dimensions in mm unless otherwise stated.



Visit Davey on-line for further information
www.davey.com.au

Davey Products Pty Ltd

Member of the GUD Holdings Ltd Group
ABN 18 066 327 517
Head Office and Manufacturing
6 Lakeview Drive,
Scoresby, Australia 3179
Ph: +61 3 9730 9222
Fax: +61 3 9753 4100
Website: www.davey.com.au
Customer Service Centre
Ph: 1300 367 866
Fax: 1300 369 119
E-mail: sales@davey.com.au
Interstate Offices
Sydney - Brisbane - Adelaide
Perth - Townsville

International

6 Lakeview Drive,
Scoresby, Australia 3179
Ph: +61 3 9730 9121
Fax: +61 3 9753 4248
E-mail: export@davey.com.au

Germany

Kantstrasse 47,
04275 Leipzig
Ph: +49 341 301 0412
Fax: +49 341 301 0413
E-mail: akrenz@daveyeurope.com

New Zealand

2 Rothwell Avenue,
North Harbour, Auckland 1330
Ph: +64 9 914 3680
Fax: +64 9 914 3685
Website: www.daveynz.co.nz
E-mail: sales@daveynz.co.nz

USA

Davey Pumps Inc.
1005 N. Commons Drive
Aurora, Illinois 60504
Ph: +1 630 898 6976
Fax: +1 630 851 7744
Website: www.daveyusa.com
E-mail: sales@daveyusa.com